

CSc 360 Operating Systems Review

Jianping Pan
Summer 2006

5/3/06

CSc 360

1

Computer Organization

- CPU
- Memory
- I/O

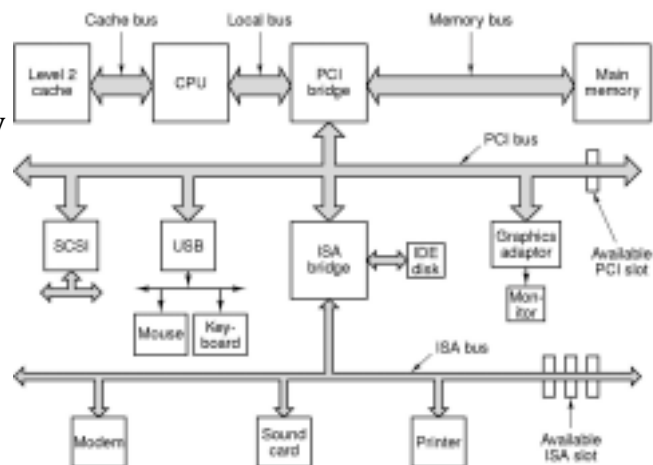

5/3/06

CSc 360

2

CPU

- Access
 - pins: address, data, control, status
- Internals
 - program counter (PC)
 - registers: address, data, control, flags
 - arithmetic logic unit (ALU), FPU, etc
- Benchmarks
 - clock (GHz), instruction/cycle, MIPS

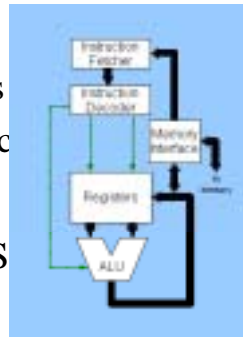
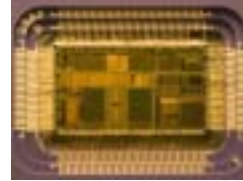

5/3/06

CSc 360

CPU operations

- Fetch
 - retrieve instructions from memory (cache)
- Decode
 - instruction: operator, operands; microcode
- Execute
 - arithmetic/logic operation
 - move data between register, memory, I/O
 - change execution flow

5/3/06

CSc 360

4

Memory

- Access
 - linear address
 - segmented address: segment, index
 - physical address: cylinder, header, sector (disk)
- Benchmarks
 - clock (MHz)
 - width (bits)
 - throughput (Mbps)

5/3/06

CSc 360

5

Memory hierarchies

- Speed vs. size (vs. cost)
 - registers: inside CPU
 - cache: transparent to programs
 - memory: main storage
 - DRAM, SDRAM, SRAM, etc
 - disks: secondary storage
 - electronic, magnetic, optical, etc
 - tapes: backup storage
 - networked storage

5/3/06

CSc 360

6

I/O

- A large variety of input/output devices
 - keyboard/mouse, video, audio, network, etc
- Access
 - Address
 - port numbers
 - I/O vs. memory space
 - Interrupt
 - Direct memory access (DMA)

5/3/06

CSc 360

7

Interrupts

- Asynchronous operation
- Nonmaskable interrupts
 - e.g., hardware fault
- Hardware interrupts
 - hardware events: e.g., I/O completion
 - interrupt controller: priority & arbitration
- Software interrupts
 - trap, system call

5/3/06

CSc 360

8

Interrupt handling

- Save current state
 - CPU counters, registers, flags at system stack
- Update program counter
 - interrupt controller; interrupt vectors
- Execute interrupt routine
- Restore previous state
- Multiple interrupts
 - priority, masking, reentry

5/3/06

CSc 360

9

DMA

- High-speed I/O, bulk data transfer
- DMA controller
 - source/destination address
 - counter: the amount of data to be moved
- DMA handling
 - program DMA controller
 - execute DMA *concurrently*
 - issue an interrupt on DMA completion

5/3/06

CSc 360

10

Computer architectures

- Single-processor systems
- Multi-processor systems
 - symmetric multiprocessing (SMP)
- Cluster systems
 - interconnected systems
- Distributed systems
 - networked systems
- Grid systems

5/3/06

CSc 360

11

This lecture

- Review computer organization and computer architecture
 - CPU, memory, I/O, interrupt, DMA
 - multiprocessor, cluster, distributed, grid
- Explore further
 - Linux with /proc
 - cpuinfo, meminfo, iomem, ioports, interrupts, dma

5/3/06

CSc 360

12

Next lecture

- An overview on operating systems
 - read OSC Chapter 1